

# Automatic Pet Water Fountain Instruction manual

Please read the instruction carefully before use and keep the instruction for reference.

## Let Love Connect Intelligence

Certificate of product  
Inspection date: \_\_\_\_\_  
The inspector: QI  
Conclusion: Qualified

### Product introduction

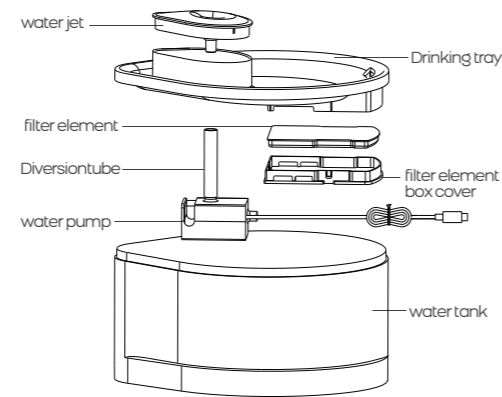

01

### Packing list

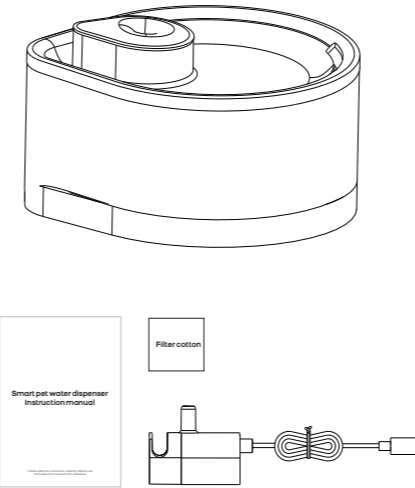

02

### Installation instructions

Before installation, clean water can be used to wash each part of the body

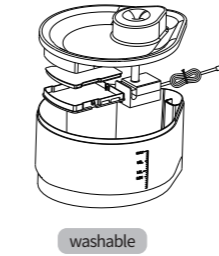

washable

The filter element is washed with water before use to remove the floating carbon produced by the activated carbon under the transport pressure.

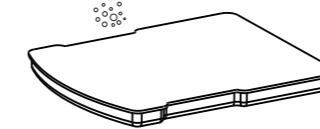

03

### Installation instructions

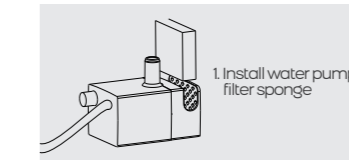

3. USB connection adapter (5V/1A recommended)



4. Install the retainer



6. Install the diversion pipe



Tip: It is recommended to replace the filter element and water pump filter sponge once a month and clean it once a week.

04

### The basic parameters

Product name: Automatic Pet Water Fountain  
Product material: PP  
Product capacity: 2.5L  
Net weight: 0.49kg  
Rated operating voltage: 5V  
Rated working power: 0.5W  
Product size: 233\*205\*135mm  
Operating temperature: 0-50 degrees Celsius  
Working humidity: 10%-80%RH  
Length of power cable: 1.5m  
Implementation standard: GB4706.1-2005

Tip: The illustrations of products and accessories in the manual are all schematic drawings for reference only. Due to the update and upgrade of the dry product, the actual product may be slightly different from the schematic diagram, so the actual product shall prevail.

05

### Non-warranty policy

- Any failure or defect caused by improper use of the environment or conditions;
- Any failure or defect caused by improper installation wrong use, unauthorized maintenance modification accident, force majeure event or other external reasons;
- Any failure or defect caused by the use of third-party accessories;
- The product has exceeded the warranty period;
- It does not meet the performance fault listed in Intelligent Pet Water Dispenser Performance Fault Table

Tip:  
1. If the returned products do not comply with the limited warranty terms our company will charge corresponding maintenance fees.  
2. This product is only sold in China (excluding Hong Kong, Macao and Taiwan), so after-sales service is only provided in China (excluding Hong Kong, Macao and Taiwan), and this warranty regulation is only applicable in China (excluding Hong Kong, Macao and Taiwan).

11

### warranty card

Warranty Card (customer deposit)

Product Name: \_\_\_\_\_ Specifications and Models: \_\_\_\_\_

Date of Purchase: \_\_\_\_\_ Invoice No: \_\_\_\_\_

Purchase address and Mall: \_\_\_\_\_

User Name: \_\_\_\_\_ Contact Number: \_\_\_\_\_

User Address: \_\_\_\_\_

Description:  
1. To facilitate accurate contact and protect your legitimate rights and interests, please fill in the above information carefully.  
2. This warranty card shall be valid only after being verified and confirmed by the salesperson on site and the user.  
3. This warranty card shall be used as the warranty basis together with the valid purchase certificate.

Warranty, replacement parts registration form

Model/Article No: \_\_\_\_\_ The product number: \_\_\_\_\_

Date of Purchase: \_\_\_\_\_ Invoice No: \_\_\_\_\_

Purchase address and Mall: \_\_\_\_\_

User Name: \_\_\_\_\_ Contact Number: \_\_\_\_\_

User Address: \_\_\_\_\_

10

### Warranty Card and warranty policy

The after-sales service of this product is implemented in strict accordance with the "Protection of the Rights and Interests of Consumers of the People's Republic of China" and "Product Quality Law of the People's Republic of China". The after-sales service is as follows:

- Within 7 days from the day after you sign the receipt, if the product has a performance fault listed in Intelligent Pet Water Dispenser Performance Fault Table, it will be tested and confirmed by after-sales service center, and you can enjoy free return or replacement service;
- Within 8-14 days from the day after you sign the receipt, if the product has a performance fault listed in Intelligent Pet Water Dispenser Performance Fault Table, it will be tested and confirmed by after-sales service center, and you can enjoy free replacement or maintenance services;
- Within 12 months from the day after you sign for receipt, if the product has a performance fault listed in Intelligent Pet Water Dispenser Performance Fault Table, it will be tested and confirmed by after-sales service center, and you can enjoy free maintenance service.

#### Performance fault list and troubleshooting

error description	treatment measure
Yellow light flashing	Reminder to replace filter element
Water pump volume is small	Check whether the water pump is properly installed and the installation direction is correct
The water pump has a different sound	Check whether the water pump enters impurities, such as hair, clean the pump impeller and filter cotton
High noise of products	Check whether the filter element and filter cartridge are installed in the drinking tray

09

### Name and content of toxic and harmful substances or elements in the product

name of parts	toxic and harmful substances or elements					
	Pb	Hg	Cd	Cr(VI)	PBB	PBDE
Water tank drinking tray	○	○	○	○	○	○
Filter cartridge water fountain	○	○	○	○	○	○
Appliance Parts	○	○	○	○	○	○
adapter	○	○	○	○	○	○
power line	○	○	○	○	○	○
water pump	○	○	○	○	○	○
filter element	○	○	○	○	○	○
accessories	○	○	○	○	○	○

○ : indicates that the content of Chinese RoHS controlled substances or elements in all homogeneous materials of the part is below the limit requirements specified in GB/T26572.  
× : indicates that the content of Chinese RoHS controlled substance or element exceeds that of at least one homogeneous material of the part. Limit requirements specified in GB/T26572.

Note: The parts in the environmental protection list include parts of different product models. The specific kind shall prevail.

In order to better care and protect the earth, when the user no longer needs this product or the product life ends. Please comply with the relevant national laws and regulations on the recycling and disposal of waste electrical and electronic products, and hand them over to local manufacturers with national recognized recycling and disposal qualifications for recycling. Improper use or disposal may affect the environment and human health.

08

### Matters needing attention

- Please use it in indoor environment;
- Disconnect the power supply when cleaning the whole machine;
- Do not clean the electric control box and power adapter. Wipe them with dry towel;
- Keep the device horizontally. Do not tip or upset the device otherwise it will lead to abnormal operation;
- Do not let pets chew the wires, otherwise the equipment may leak electricity, there is a danger of electric shock;
- If children use the device, please make sure to use the device under adult guidance;
- Do not use hot water in the tank;
- Do not disassemble or repair the product device without authorization;
- Do not use non-professional accessories, the company is only responsible for the performance and safety of accessories provided by the official;
- In order to provide better products, we will carry out product improvement regularly;
- The product picture is slightly different from the object please take the object as the standard.

07

### Care and maintenance

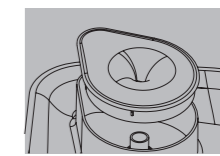

Remove the sprinkler for cleaning

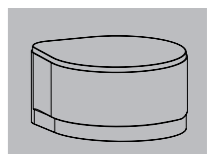

Drinking basin cleaning

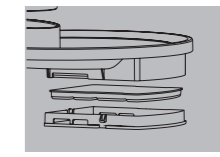

Remove the filter cotton and filter cartridge box for cleaning

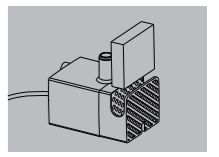

Remove water pump, remove filter cotton and clean

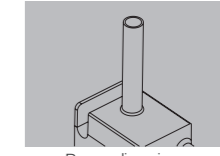

Pump diversion tube cleaning

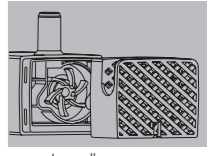

Impeller cover impeller cleaning

06